

SUPERIOR  
**SE**  
ENGINEERING  
**COIL RAM**

Superior Engineering's carriage mounted coil ram offers a solution to coil handling requirements. Manufactured from the highest quality steel and workmanship, these coils perform under constant usage. The mountings are available in all ITA mounting classes and Non-ITA mounting as well. A locking pin is used to secure the coil ram to the carriage. Standard diameters from 4" to 16" and lengths from 24" to 72" are available. Special sizes are available upon request. Refer to our specification sheet for weights, capacities, HCG's, VCG's and LLC's.

BLUNT NOSE IS STANDARD



ITA MOUNT STYLE

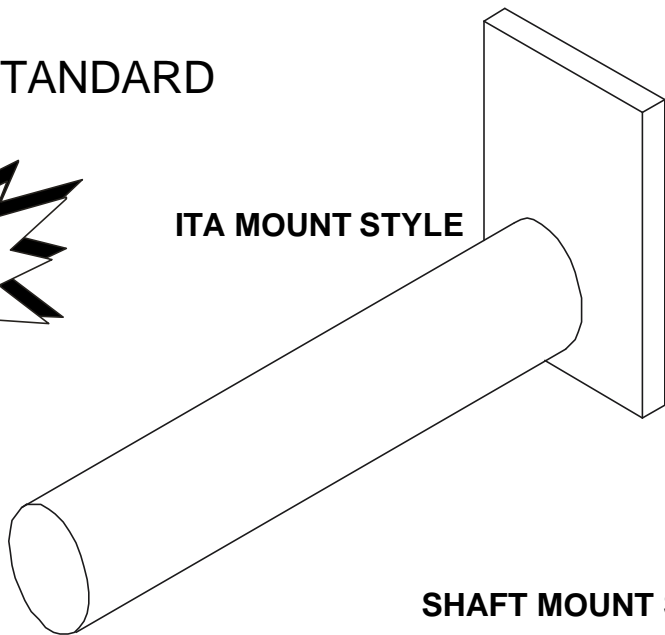

SHAFT MOUNT STYLE

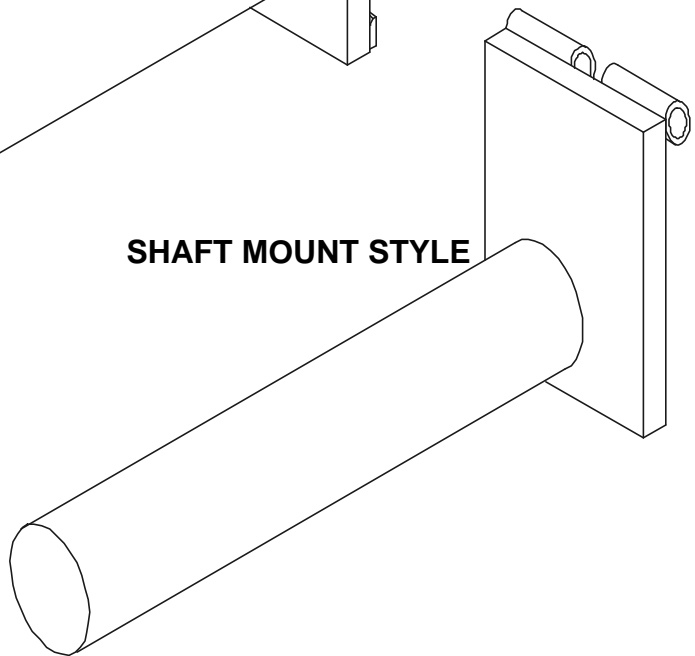

**SUPERIOR ENGINEERING, PO BOX 547, BELTON, SC 29627**  
**TEL (864) 226-8799 OR 1-800-359-3052 FAX (864)231-6718**  
**WEBSITE ADDRESS: WWW.SUPERIORENG.COM**