

# SE SUPERIOR ENGINEERING

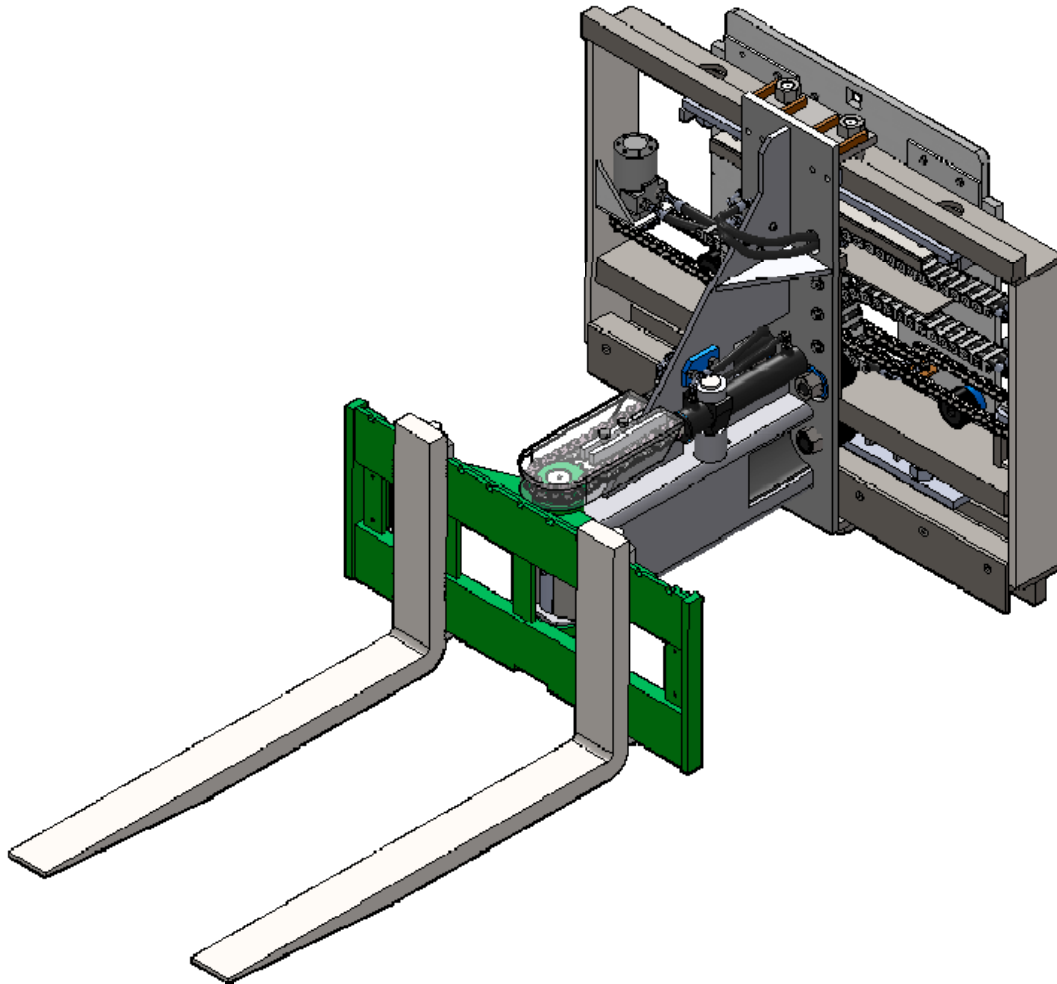

**TURRET  
MASTER  
ATTACHMENT**

**GENERATION-III TURRET : PARTS  
AND SERVICE MANUAL**

WWW.SUPERIORENG.COM | 1-864-226-8799

<u>CONTENTS</u> .....	<b>Error! Bookmark not defined.</b>
<u>TURRET HEAD INSTALLATION</u> .....	2
<u>INSTALLATION INSTRUCTIONS:</u> .....	2
<u>OPERATING THE ATTACHMENT:</u> .....	2
<u>OPERATIONAL RECOMMENDATIONS:</u> .....	2
<u>ADJUSTMENTS:</u> .....	3
<u>MAINTENANCE:</u> .....	3
<u>A. 200 HOUR OR MONTHLY CHECK</u> .....	3
<u>B. 1000 HOUR OR 6 MONTH CHECK</u> .....	3
<u>C. 2000 HOUR OR ONE YEAR CHECK</u> .....	3
<u>ATTACHMENT WARRANTY</u> .....	5
<u>WARRANTY POLICY</u> .....	6
<u>LUBRICATION CHART</u> .....	7
<u>TURRET HEAD ASSEMBLIES</u> .....	8
<u>TORQUE SPECIFICATIONS</u> .....	9
<u>FIXED FRAME ASSEMBLY</u> .....	10
<u>INTERMEDIATE FRAME ASSEMBLY</u> .....	11
<u>CARRIAGE ASSEMBLY</u> .....	13
<u>PIVOT BOOM ASSEMBLY</u> .....	14
<u>SERVICE BULLETIN</u> .....	16
<u>SERVICE BULLETIN</u> .....	<b>Error! Bookmark not defined.</b>

## TURRET HEAD INSTALLATION

### **INSTALLATION INSTRUCTIONS:**

The hanger brackets welded on the back of the attachment conform to the specifications of the mast. Install the mast roller bearing kit according to the mast manufacturer's manual. Measure the inside dimensions of the mast channel and the outside dimensions of the roller bearings and shim the bearings to the manufacturer's specifications.

The thrust bearings that roll on the outside or inside of the mast rail should be loosened and adjusted away from the mast rail for installation. Before installing the turret head, check the hydraulic supply group installed internally or externally on the mast for compatibility with the attachment. Hydraulic pressure must not exceed 2500 p.s.i., The pivot circuit requires only 1 GPM for proper activation but will work well up to 5 GPM. The side shift circuit requires a minimum of 5 GPM and works well up to 10 GPM. Connect the hoses for compatibility to the directional markings on the control valve handles. After all connections are completed adjust the thrust bearings to touch the mast rail.

After all connections have been secured raise the mast to check for interference between the attachment and mast parts. After all connections are checked for safe operation, remove any foreign particles of debris from the attachment bearing tracks. Lower the attachment to a safe working level and operate without a load to eliminate any air in the hydraulic circuits. Recheck all connections for possible hydraulic leaks or mechanical interference. Load the attachment and operate both hydraulic functions and check for hydraulic leaks of mechanical problems.

### **OPERATING THE ATTACHMENT:**

- Check the attachment specifications (capacity, load size etc.)
- Check the load specifications to insure compatibility with the truck/attachment combinations. Your forks should not exceed the length of your load and should be adjusted as wide apart as your load will accept.

### **OPERATIONAL RECOMMENDATIONS:**

- Travel with the load in a lowered position. This will increase the truck stability and operator visibility.
- Operate the rotation and side shifting functions at low speed.
- Store the heaviest loads in the lower storage positions.
- Do not side shift the attachment when loaded unless the lift truck is in a storage rack area or in a lowered position.
- Do not rotate the turret attachment when loaded unless your load is in a lowered position.

## **ADJUSTMENTS:**

1. Traverse chain adjustment
2. See traverse chain-adjust sheet.
3. Adjust the rotation speed by means of the flow valves at the top of the pivot head area. Recommended speed is 6 to 8 seconds.
4. The double pilot lock valve is fixed therefore adjustment is not required.

## **MAINTENANCE:**

The turret head attachment in most applications needs to be serviced after 200 hours. It is highly recommended to visually check the attachment daily for obvious problems. Always inspect the attachment after any collisions, shocks, or unusual noises.

### **A. 200 HOUR OR MONTHLY CHECK**

- Observe all bearings and tracks
- Hydraulic hoses and track assembly
- Check traverse chain adjustment
- Chain tensions during rotation - \*See rotation assembly drawing\*

### **B. 1000 HOUR OR 6 MONTH CHECK**

- Perform all operations above.
- Clean all moving parts
- Clean the rotation chain. Inspect the condition of the chain and connection links. Lubricate with oil or light grease.<sup>1</sup>
- Clean and inspect the traverse chain assembly
- Locate the grease fitting for the pivot shaft and grease.
- Grease the eight main load bearings.
- Check all structural assemblies and the bolt on parts for tightness.

### **C. 2000 HOUR OR ONE YEAR CHECK**

- Perform all operations on paragraph (a) and (b).
- Inspect the chain; any excessive wear in the pin connection requires replacement.
- Inspect all roller bearings; any surface imperfection or noise during operation requires replacement.
- Inspect rotation assembly; any excessive wear will require the replacement of the bushings.
- Inspect forks. Any cracks in the fork require replacement. Pay particular attention in the area of the heel and hooks. Inspect for wear on the bottom of the heel. 10

---

<sup>1</sup> Refer to specification page and lubrication chart

percent wear reduces capacity 50 percent. Welding cannot repair forks. Only replacement is acceptable.

Inspect all hydraulic connections and components. For specific repair, refer to individual repair instruction sheets.

# SUPERIOR ENGINEERING, INC.

## ATTACHMENT WARRANTY

SUPERIOR ENGINEERING WARRANTS ITS NEW LIFT TRUCK ATTACHMENTS TO BE FREE OF DEFECTS IN MATERIAL AND WORKMANSHIP, UNDER NORMAL USE AND SERVICE FOR A PERIOD OF SIX (6) MONTHS FROM DATE OF DELIVERY TO ORIGINAL PURCHASER.

SUPERIOR ENGINEERING WARRANTY LIABILITY IS LIMITED SOLELY TO REPAIR OR REPLACEMENT OF ANY PART OR EQUIPMENT RETURNED TO OUR PLANT, FREIGHT PREPAID, AND DETERMINED BY US TO BE DEFECTIVE. SUPERIOR ENGINEERING SHALL NOT BE LIABLE UNDER ANY CIRCUMSTANCES FOR CONSEQUENTIAL OR INCIDENTAL DAMAGES.

EXCEPT FOR REMOVAL OF DEFECTIVE PARTS AND REPLACEMENT WITH PARTS SUPPLIED BY SUPERIOR ENGINEERING, THE WARRANTY FOR ANY PART OR EQUIPMENT WILL BE VOID IF AN ATTEMPT IS MADE BY ANYONE TO ALTER, REPAIR, OR DISASSEMBLE THE ITEM WITHOUT THE AUTHORITY OF SUPERIOR ENGINEERING.

SUPERIOR ENGINEERING MAKES NO OTHER WARRANTY OF ANY KIND WHATSOEVER, EXPRESSED OR IMPLIED; AND ALL IMPLIED WARRANTIES OF MERCHANTABILITY, FITNESS FOR A PARTICULAR PURPOSE, AND ALL CLAIMS BASED ON MISUSE, NEGLIGENCE, STRICT LIABILITY, IMPROPER MAINTENANCE, OR OTHERWISE, ARE HEREBY DISCLAIMED BY SUPERIOR ENGINEERING AND EXCLUDED FROM THIS AGREEMENT.<sup>2</sup>

---

<sup>2</sup> 07-01-03 ATTACHMENT WARRANTY

# SUPERIOR ENGINEERING

## WARRANTY POLICY

### **SUPERIOR ENGINEERING'S WARRANTY POLICY WILL BE ADMINISTERED IN ACCORDANCE WITH THE FOLLOWING GUIDELINES:**

- THE WARRANTY POLICY PROVIDES FOR PAYMENT OF WARRANTY LABOR ON NEW ATTACHMENTS AT 75 % OF DEALER'S PUBLISHED RETAIL LABOR RATE.
- LABOR HOURS PAID WILL BE LIMITED BY SUPERIOR ENGINEERING'S STANDARD LABOR TIME SCHEDULE UNLESS PRIOR APPROVAL FOR DEVIATION IS OBTAINED FROM A SUPERIOR ENGINEERING SERVICE REPRESENTATIVE.
- LIFT TRUCK MODIFICATIONS FOR VARIOUS ATTACHMENT APPLICATIONS ARE NOT CONSIDERED WARRANTY.
- TROUBLESHOOTING TIME IN EXCESS OF ONE HOUR MUST HAVE THE PRIOR APPROVAL OF A SUPERIOR ENGINEERING SERVICE REPRESENTATIVE.
- TRAVEL TIME IN EXCESS OF ONE HOUR MUST HAVE THE PRIOR APPROVAL OF A SUPERIOR ENGINEERING SERVICE REPRESENTATIVE.
- WARRANTY REPAIR WILL NOT BE HONORED FOR AMOUNTS EXCEEDING THE COST OF THE ATTACHMENT OR ACCESSORIES.
- SUPERIOR ENGINEERING'S WARRANTY CLAIM FORM MUST BE USED TO SUBMIT CLAIMS. ANY WARRANTY SENT TO SUPERIOR ENGINEERING ON NORMAL INVOICES WILL BE RETURNED.
- THE WARRANTY CLAIM FORM SHOULD BE COMPLETED ACCURATELY AND WITH AS MUCH DETAIL AS POSSIBLE.
- PLEASE CONTACT A SUPERIOR ENGINEERING REPRESENTATIVE TO OBTAIN A WARRANTY CLAIM NUMBER AND A RETURN GOODS AUTHORIZATION (RGA) NUMBER AS REQUIRED.
- WARRANTY CLAIMS MUST BE SUBMITTED WITHIN 30 DAYS OF MALFUNCTION DATE.
- GOODS ON RGA'S MUST BE RETURNED WITHIN 10 DAYS OF RGA ISSUE DATE UNLESS AUTHORIZED BY SUPERIOR ENGINEERING SERVICE REPRESENTATIVE.
- IN THOSE CASES WHERE SUPERIOR ENGINEERING HAS SUPPLIED COMPONENTS/ACCESSORIES NOT MANUFACTURED BY SUPERIOR ENGINEERING, THE ORIGINAL MANUFACTURER'S WARRANTY SHALL APPLY.

### **STATEMENT TO DEALERS**

**WARRANTY REPAIRS SHOULD NOT BE CONSIDERED AN AREA FOR PROFIT. IF YOUR COMPANY HAS THIS PHILOSOPHY, PLEASE LOOK FOR AN ALTERNATIVE SOURCE FOR THESE PRODUCTS.**

## LUBRICATION CHART

The following lubricants are recommended for all bearings:

MANUFACTURER	TYPE
SHELL	ALVANIA EP2
EXXON	RONEX WB
TEXACO	MULTIFAX EP2
MOBIL	MOBILUX EP2
UNION	UNOBA EP2
SUN	PRESTIGE 742 EP

Lubricants of the same quality by others may also be used.

Any light oil, such as motor or hydraulic oil, can be used to lubricate chain pivot points.

## TURRET HEAD ASSEMBLIES

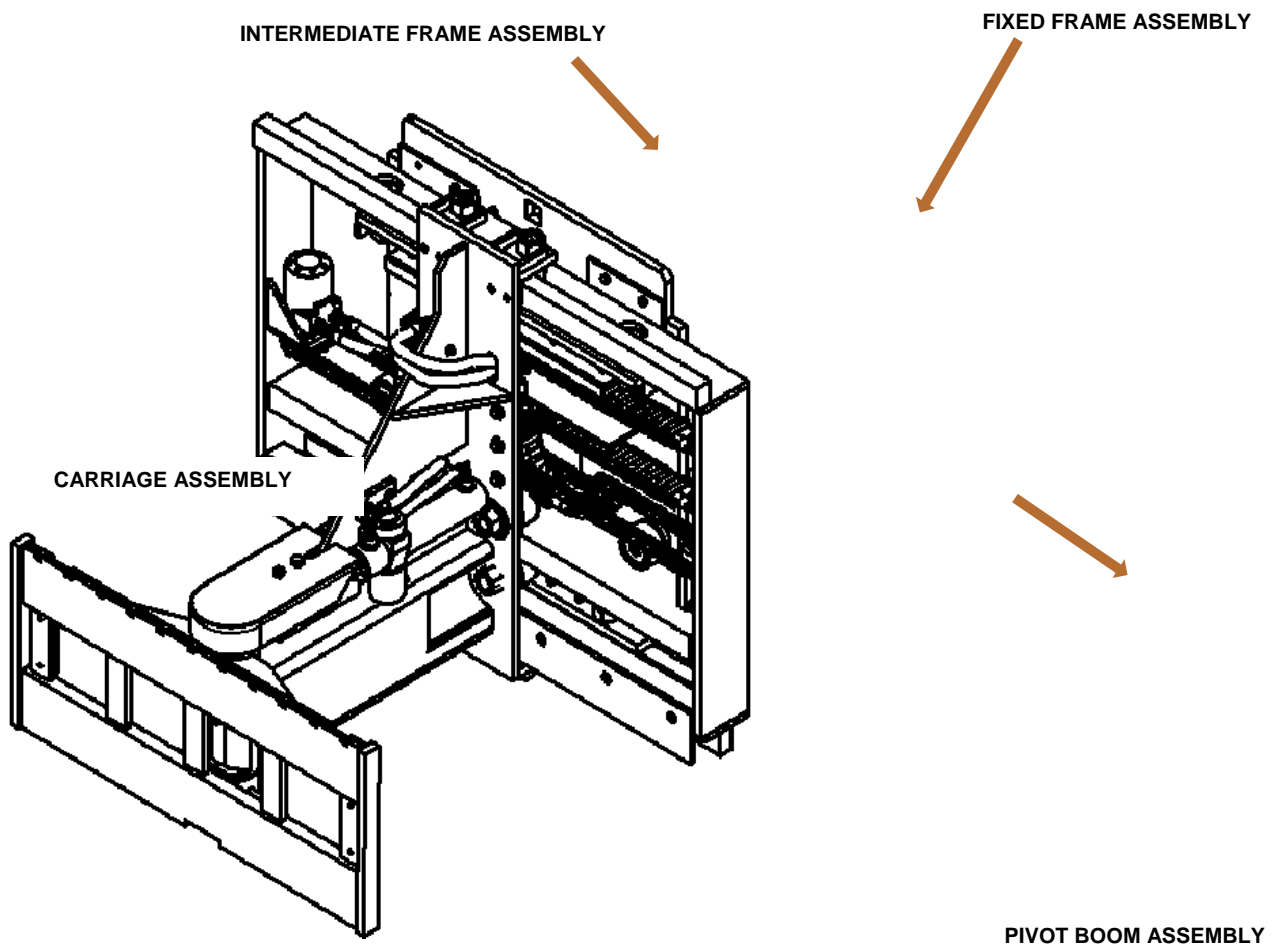

## TORQUE SPECIFICATIONS

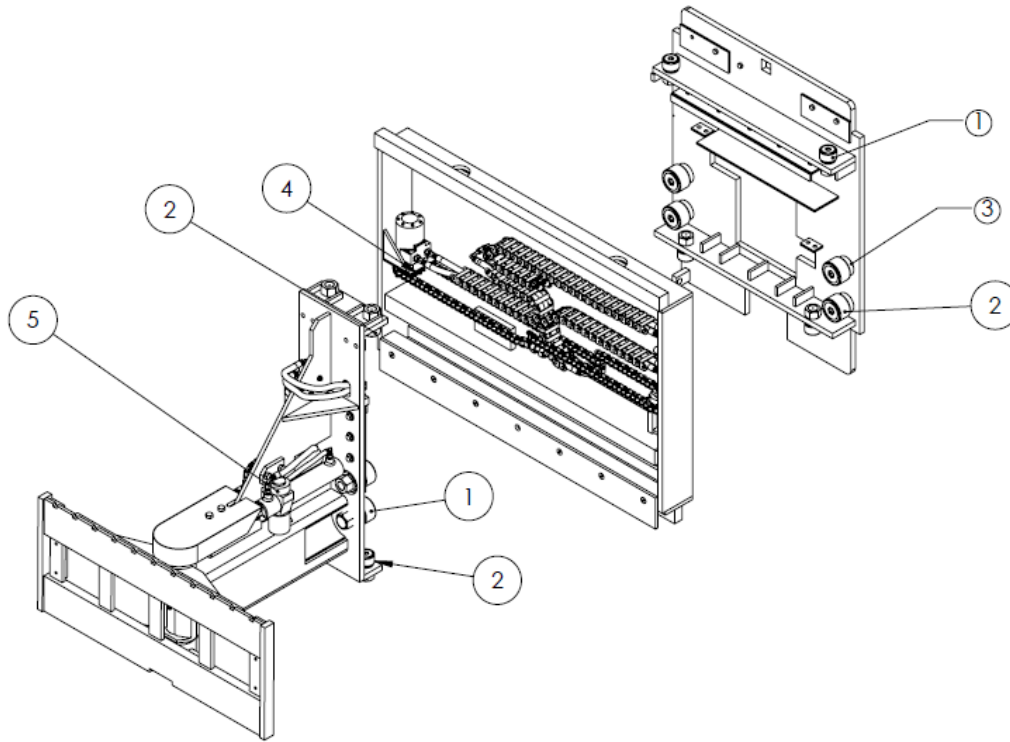

ITEM NO.	QUANTITY	DESCRIPTION	TORQUE (FT/LBS)
1	8	MAIN LOAD BEARINGS	425
2	14	ROLLER BEARINGS	235
3	4	THRUST BEARING STUD	55
4	4	MOTOR BOLTS	45
5	2	PIVOT CYL. MOUNT BOLTS	50

# FIXED FRAME ASSEMBLY

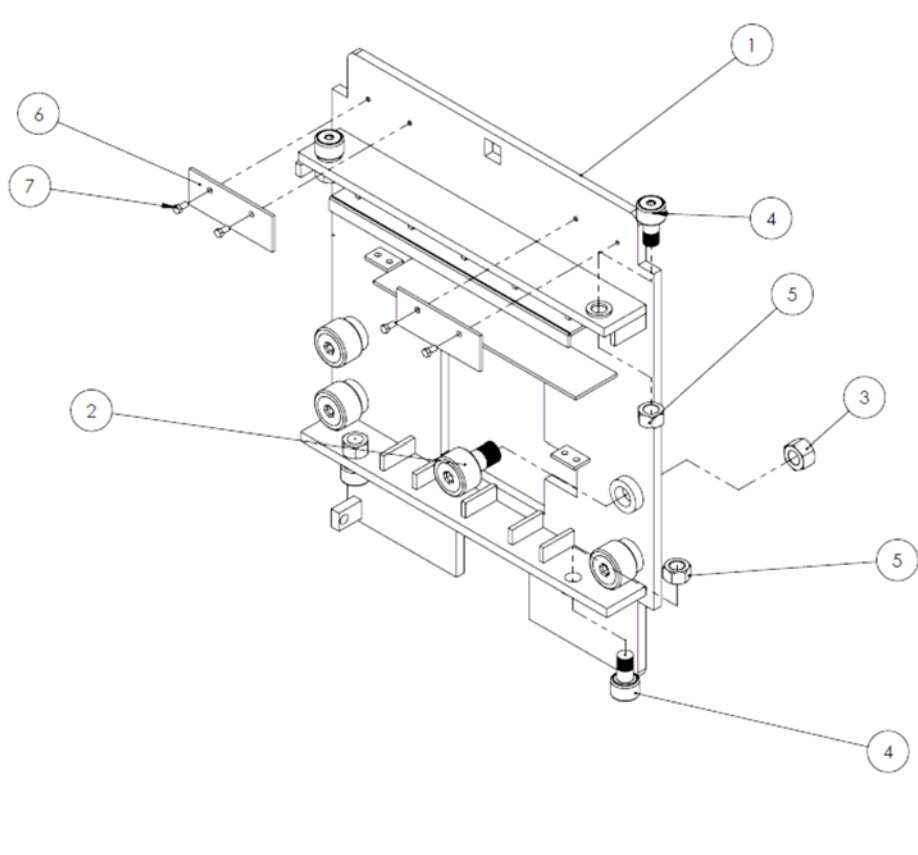

S. NO	QTY REQ'D	PART NO.	DESCRIPTION
1	1	29292-011	FIXED FRAME WELDMENT
2	4	8355	LOAD BEARING
3	4	9104	LOAD BEARING NUT
4	8	8357	ROLLAR BEARING
5	8	9110	ROLLER BEARING NUT
6	2	29292-044	UHMW WEAR STRIP
7	4	9123	UHMW SCREW

## INTERMEDIATE FRAME ASSEMBLY

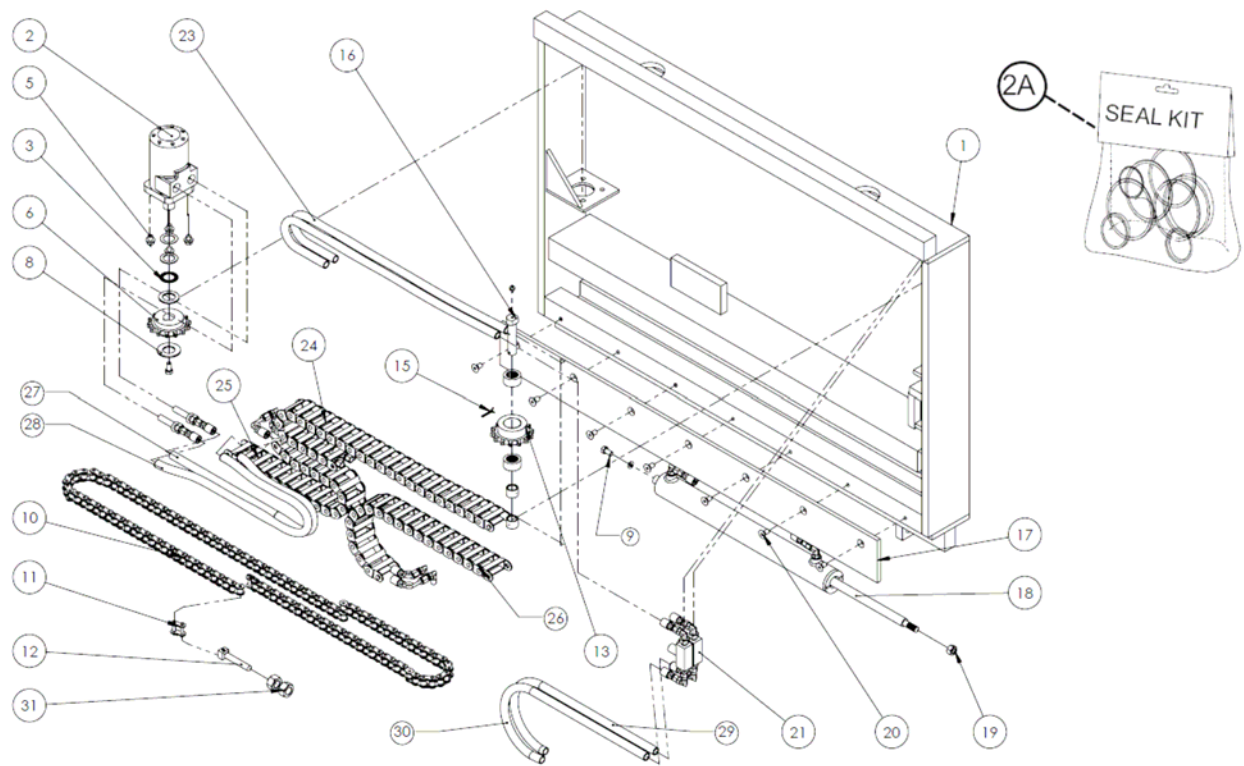

S. NO	QTY REQ'D	PART NO	DESCRIPTION
1	1	29292-031	Intermediate frame weldment
2	1	306027C	Drive motor
2A	1	SE1000C	Seal kit
3	1	SE1002	Thrust bearing kit
5	4	9113	Bolt and lock washer
6	1	8376A	Drive sprocket
8	1	SE1003	Sprocket bolt kit
9	1	304449	Bolt
10	1	8386	Drive chain for 48" stroke units
11	2	60M	Master link
12	1	8385	Chain adjuster
13	1	8501	Idler sprocket
15	1	8384	Cotter pin
16	1	8381	Idler sprocket pin
17	1	29292-019	Plate
18	1	8327	Side-shift cylinder

19	1	304464	Lock nut
20	7	36833	Socket head cap screw
21	2	8321	Flow control valve
23	2	8369	Upper hydraulic hose
24	1	8350	Upper hydraulic hose track
25	1	8356	Middle left hydraulic hose track
26	1	8358	Lower right hydraulic hose track
27	1	8364	Middle left hydraulic hose
28	1	8365	Middle left hydraulic hose
29	1	8366	Lower right hydraulic hose
30	1	8367	Lower right hydraulic hose
31	1	31215	Lock nut

## CARRIAGE ASSEMBLY

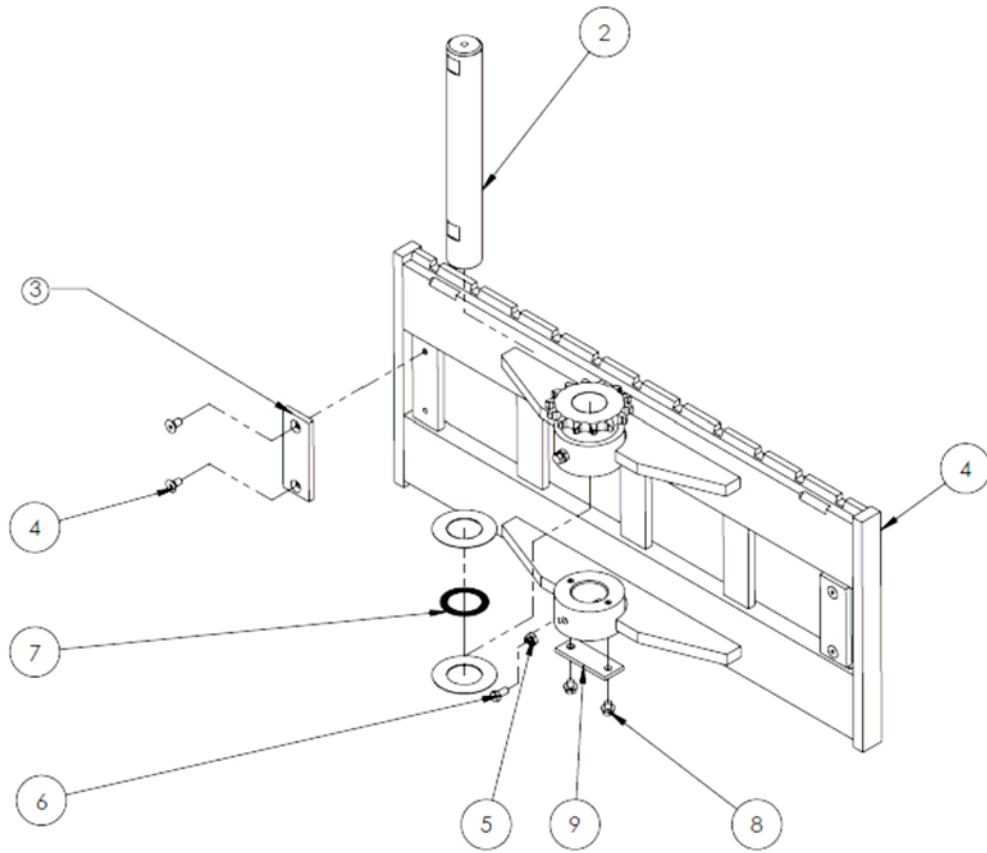

S.No	QTY REQ'D	PART NO.	DESCRIPTION
1	1	8206A	CARRIAGE WELDMENT
2	1	8382	PIVOT SHAFT
3	2	8374	UHMW STOP BLOCK
4	4	9108	FASTENER
5	2	9102	JAM NUT
6	2	9101	MODIFIED FASTENER
7	1	8368	BEARING KIT-2 WASHERS, 1 BEARING
8	2	30050/31327	HEX SCREW W/ WASHER
9	1	250018	SHAFT PLATE

## PIVOT BOOM ASSEMBLY

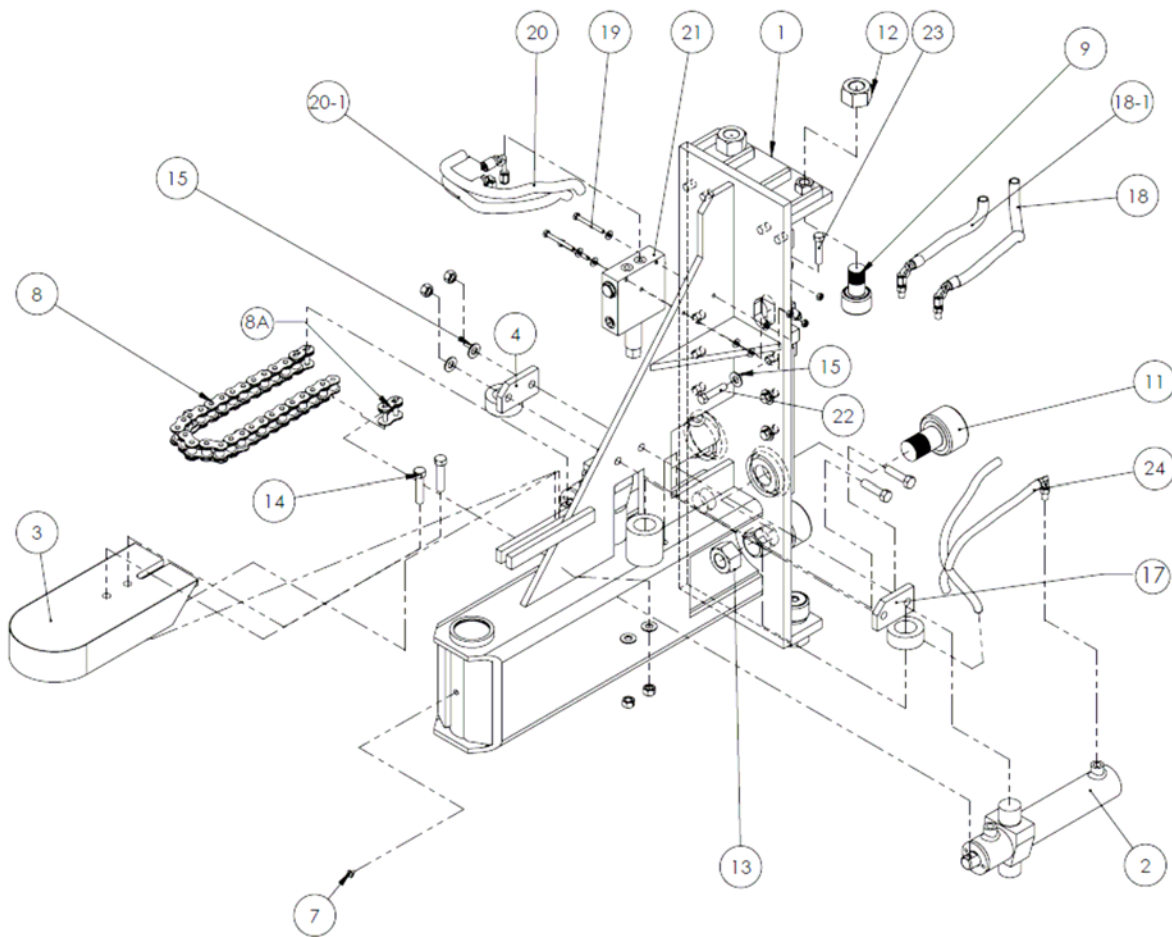

S.No	QTY REQ'D	PART NO.	DESCRIPTION
1	1	8202B	pivot boom weldment
2	2	8326	Pivot cylinder
3	1	8380	Pivot chain guard
4	1	8397	Left pivot cylinder mount
7	1	8393	Grease fitting
8	1	8351	Pivot chain
8A	2	8352	Master link w/ 2 side plates
9	4	8357	2" roller bearing
11	4	8355	3" roller bearing
12	4	9110	2" roller bearing nut
13	4	9104	3" roller bearing nut
14	1	8395	Chain guard bolt kit

15	1	8396	Pivot cylinder mount bolt kit
17	1	8398	Right pivot cylinder mount
18	1	8407	Hydraulic hose
18-1	1	8406	Hydraulic hose
19	1	30010	Hydraulic valve bolt kit
20	1	8402	Hydraulic hose
20-1	1	8403	Hydraulic hose
21	1	83241	Pivot valve
22	1	8404	Bolt kit
23	2	8405	Bolt kit
24	2	8336	Reservoir hose

## SERVICE BULLETIN

### **Subject:** *Turret Traverse Chain Adjustment 12-11-09*

A hydraulic or electric motor operates the turret traverse function, consisting of a drive sprocket, idler sprocket, and a No. 60 chain. The chain connects to the back of the pivot boom assembly, one end is fixed and the other is connected to an adjustable chain anchor. A  $\frac{3}{4}$ " open-end wrench and a  $\frac{3}{4}$ " deep well socket and ratchet are required to adjust the chain.

Check the idler sprocket and drive motor sprocket for wear if adjustment is a consistent problem. The bearing in the idler sprocket also needs to be checked, if worn, replace the idler sprocket.

A new chain will stretch after the first 12 hours of service and will require adjustment. The chain also has to be adjusted as the components wear. The correct amount of chain tension is a critical adjustment. To our knowledge, no tool or measuring device is available for measuring chain tension nor does any chain manufacturer specify the correct amount of chain tension. A chain that is too tight can damage the drive components. A slightly loose chain is better than an over tightened chain. The tension only needs to be tight enough for the chain to pull the load without sagging. Watch the chain as the adjustment is tightened. As soon as the slack is out of the chain and it is straight, stop. Operate the traverse and observe the chain. If there is a vibration, the chain is too tight. Adjust the chain tension until the chain is straight and does not vibrate.

Recheck the adjustment after an hour of operation if the chain is used and 12 hours if the chain is new.

Chain adjustment should be a part of your standard preventative maintenance program. For help call 1-800-359-3052.

## SERVICE BULLETIN

### **Subject:** *Side Shift Cylinder Repair*

The side shift cylinder for the turret is located inside the intermediate frame above the load bar and is mounted horizontally. The base end is connected to the fixed frame and the rod end to the intermediate frame. The side shift cylinder provides the lateral shift of the intermediate frame. The side shift cylinder is a simple double acting hydraulic unit. Oil is held under pressure on both ends.

Please follow the procedure listed below to repair or replace the side shift cylinder:

1. Side shift the boom and intermediate frame to the right (from the drivers seat) to the end of the stroke. Disable truck.
2. Remove the hydraulic hose from each end of the cylinder.
3. Remove the nut from the rod on the rod end of the cylinder where it connects to the intermediate frame.
4. Remove the bolt and washer from the base end of the cylinder where it connects to the fixed frame, manually push the intermediate frame to the left and remove the cylinder.
5. The rod end of the cylinder is full of oil, please dispose of the oil in an environmentally responsible way.
6. The side shift cylinder has a screw-in head that has standard right hand threads in the barrel or the rod end. Using the correct spanner wrench, remove the head. The rod, head and piston can now be removed.
7. Remove the nut on the piston end of the rod and remove the piston. The head can then be removed from the rod. Clean all parts and replace as necessary.
8. Study the seal locations and lay out the new seals in the correct order before removing the old seals. Replace all seals.

9. Slip the head on to the rod from the piston end so the internal rod seal will not be damaged. The direction of installation from the piston end allows the rod to slide through the rod seal in a direction that does not damage the rod seal.
10. Be careful to install the small o-ring on the step down rod area where the piston goes. Install piston and nut.
11. Oil the piston and barrel. Slide piston into barrel until the head rests against the internal threads of the barrel. Screw in until it is tight.
12. Install cylinder; reverse steps 2, 3 and 4.
13. Restart truck, side shift to the left slowly and then to the right slowly. After several cycles at slow speeds increase the speed and hold the lever for 1-2 seconds at the end of each full side shift stroke. Side shift the boom and intermediate frame to the right, turn truck off, set parking brake.
14. Check for visible signs of a leak.
15. Update truck service records.
16. Recheck truck after eight hours of service.

## SERVICE BULLETIN

### **Subject:** *Pivot Cylinder Repair*

Pivot cylinders are simple hydraulic units and are easy to repair. The pivot cylinder has three areas that can leak, the rod seal, the O-ring around the outside of the head or an internal leak by the piston packing that allows excessive fluid to exit through the breather port at the base of the cylinder. After verifying the cylinder is leaking follow the steps below for removal:

1. Pivot the carriage to retract the cylinder that is leaking. Disable truck before starting work.
2. Remove two ½” bolts from the chain guard and remove the guard.
3. Remove the hydraulic pressure hose and breather hose from the cylinder. Disconnect the chain.
4. Remove the two bolts, holding the bracket that retains the cylinder and remove the cylinder.
5. The cylinder is full of oil. Please drain the oil in an environmentally friendly container and dispose of properly.
6. A workbench with a vise is very helpful when rebuilding hydraulic cylinders.
7. The replacement cylinder seal kit part # is 2803168.
8. Remove the internal snap ring from the cylinder barrel in the rod end. After the snap ring is removed the head, rod and piston assembly can be removed from the barrel.
9. Clean and inspect the barrel for scratches or gouges that can cause seal failure. After insuring that the barrel is ok for repair, proceed by removing the piston from the rod and slide the head off of the rod.
10. Layout new seal kit (2803168) identifying the location of each seal. Look for the seal on the inside of the head and for the o-ring under the piston. These are easy to miss. After insuring the exact location of each seal, remove the seals from the head and replace them. Slide the head back onto the rod starting from the piston end. This lets the rod enter in the same direction as the cup on

the internal seal and assures no damage is done to the seal during installation. Next put the small o-ring on the rod at the piston end. Slide the piston on and then install and tighten the nut. Install the piston seals.

12. Oil the piston and barrel. Slide the piston into the barrel and push the head down into the cylinder barrel. Install the snap ring.

13. Install cylinder, reverse steps 3 and 4 for reassembly.

14. Restart truck; watch the pivot chain, keep it in place. Pivot slowly until the chain is tight. Pivot several times back and forth. Speed up the pivot and hold for 1-2 seconds at the end of each pivot right and left.

15. Check for leaks.

16. Update truck service records.

17. After eight hours of service, check for leaks.

SERVICE BULLETIN

**From:** *Superior Engineering, Inc.*

**To:** *Warranty and Servicing Personnel*

**Subject:** *Warranty Claims for broken Pivot Chains*

Broken chains are not covered under warranty. The force of the hydraulic cylinders can not break the pivot chain. The maximum force a cylinder can place on the pivot chain is 6000 lbs. with the lift trucks hydraulic pressure set at 2750 PSI. The No. 80 pivot chains shear strength is 17,800 lbs., which is three times the amount of force the cylinder can place on the chain. The only way a chain or master link breaks is for the operator to drive the fork carriage into stationary objects. The average turret truck weighs 10,000-12,000 lbs. The moving force of this much weight can break the chain. Please inform the end user of this situation. Proper use of the Turret Attachment through operator training will eliminate this problem.

The chain master links are special links made for Superior Engineering, Inc. If they are replaced with standard master links, they will fail. Please contact Superior for the correct replacement master links. Please contact Superior Engineering, Inc. with any questions. 1-800-359-3052

# Service Bulletin

**To:** *Servicing Personnel*

**Subject:** *Pivot Chain Repair*

The No. 80 chain (part # 8351) that connects the pivot cylinders must be aligned properly with the sprocket on the carriage to insure the correct rotation in both directions.

Remove two ½” bolts and nuts in the chain guard and remove the guard. Disassemble the chain and master links and remove from the boom area. To replace the chain or master links, manually pull the cylinders out approximately half of the stroke. The hydraulic lever on the truck must be pushed or pulled to allow the oil to flow out of the cylinder and into the trucks hydraulic tank.

The truck should not be running. After one cylinder is extended, reverse the lever to extend the other cylinder.

Note the trucks hydraulic pressure will not extend the cylinders, the cylinders are plumbed only for retraction. Turn the carriage to the front. The chain sprocket on the carriage has a tooth aligned to the front. The center chain link must be lined up here. Roll the chain around the sprocket and connect the chain with the special heavy-duty master links (part # 8352) to the cylinders. Do not use standard No. 80 master links, they will fail prematurely. With the truck hydraulics on, slowly activate the hydraulic valve and tighten the chain in one direction. Do not retract anymore than is required to tighten the chain. Reverse the valve and tighten the other side. The chain should be tight on both sides. Slowly pivot the carriage in both directions making sure that the carriage pivots all the way in both directions. If the carriage does not pivot all of the way in both directions, the chain is not centered on the sprocket.

After assuring the chain is centered, rotate slowly in both directions several times. Speed up the rotation and hold for 1-2 seconds at the end of each pivot right and left.

Check for leaks.

Turn the truck off and reinstall the chain guard.

Update the truck service records.

Check for leaks after eight hours of service.

# Service Bulletin

**From:** *Superior Engineering, Inc.*

**To:** *Servicing Personnel*

**Subject:** *The presence of hydraulic oil in the Pivot Boom Weldment structure*

The internal frame structure of the Pivoting Boom on the Superior Turret attachment acts as a hydraulic blow-by reservoir for the pivot cylinder breather lines. The pivot cylinders are single acting and hydraulic pressure is controlled in the rod end only. The cylinders are used separately to pivot in opposite directions. When either cylinder is retracting to pivot the carriage, the pulling force of the chain is extending the opposite cylinder as the chain is connected to both cylinders. The pivot cylinders never extend under pressure they only retract. Hydraulic pressure is never present in the base end of the cylinder. There is only a small amount of oil blow-by from the seals inside the base end of the cylinder. The base end of each cylinder has a low-pressure hose that is inserted into a drilled hole in the top of the pivot boom weldment structure. This acts as a reservoir to contain the oil blow-by until the scheduled maintenance. A drain plug is in the bottom and the plug should be removed and the oil drained before replacing the plug. Normally, the amount of oil should not exceed one quart over a 1-2 month period. If the volume is more, the pivot cylinder seals are reaching the point where replacement is necessary. If you should find that the reservoir is full, the seals have failed and require immediate replacement.

The pivot cylinders will continue to pivot the load and appear to function properly even if an internal leak is present. A careful monitoring of the amount of oil drained from the reservoir during scheduled maintenance can provide an early warning of the deterioration of the seals. Maintenance can then be scheduled for a minimum down time of the truck and cost to the end user. Please call Superior Engineering, Inc. at 800-359-3052 if you have any additional questions or suggestions regarding this bulletin.

# Service Bulletin

**To:** *Servicing Personnel*

**Subject:** *Replacement of boom and traverse frame*

The boom assembly must be removed before the Traverse frame can be removed.

## **BOOM REMOVAL**

Disconnect the hosing in the tracking on the top of the boom that connects to the top of the fixed frame. Tilting units have four hoses and non-tilting units have two.

Remove the ½” nut (¾” deep well socket required) that connects the traverse chain and adjuster to the boom.

Remove the master link from the pivot chain on the fixed connection then remove the chain from the boom.

The boom has three cam type roller bearings on top and bottom that roll in the traverse frame tracks. This is a total of six bearings. The 1-1/8”(1-11/16” socket size) nuts that retain the bearings are accessible from the top and bottom.

Side-shift the traverse frame to the right until the maximum travel is reached. Access holes in the top and bottom of the track allow the bearings to be removed.

Roll the boom over to the right side of the traverse frame and line the bearing up with the access hole. A 3/8” Allen head hex tool is required to hold the stud in the bearing while the nut is removed.

Repeat this on the remaining bearings. Once all bearings are removed the boom is ready to lift off the Traverse frame.

The boom is very heavy; assistance with a hoist is required.

## **TRAVERSE FRAME REMOVAL**

Once the Boom is removed the traverse frame can be removed.

Disconnect the two hoses, which connect to the hydraulic motor that operates the traverse chain.

Disconnect the side shift cylinder rod end from the traverse frame. This is a ½” nut and has a ¾” wrench size.

The traverse frame has four cam type roller bearings on top and bottom that roll in the traverse frame tracks. This is a total of eight bearings. The 1-1/8”(1-11/16” socket size) nuts that retain the

bearings are accessible from the top and bottom. Side-shift the traverse frame to the right and left until the access holes in the top and bottom of the track allow the bearings to be removed. A 3/8" Allen head hex tool is required to hold the stud in the bearing while the nut is removed. Repeat this on the remaining bearings. Once all bearings are removed the traverse frame is ready to lift off the fixed frame. The traverse frame is very heavy; assistance with a hoist is required. For installation, please reverse these procedures.

# SERVICE BULLETIN

**To:** *Servicing Personnel*

**Subject:** *Metal chips and wear tracks in the turret mast*

Mast channel is made of a special metal, but is not heat treated. The extruding process leaves a shallow soft surface that tends to flake off under pressure when new. Standard forklift masts have little side loading and the wear patterns can not be compared to the wear of a turret mast.

All turret masts will have some immediate wear to the side thrust-bearing path. The load offset from the centerline of the mast to the center of the load and the weight of the load determine how quickly the wear will start. Masts with more offset and heavier weights will wear more than a light load with fewer offsets. Metal flakes will accumulate at the bottom of the mast area in-line with the bearings. The wear in process will diminish after 500-1000 hours.

During this time, perform a weekly inspection of the bearings and mast. Please wear safety glasses and gloves, as some sharp edges may be present. Remove the metal flakes at the base of the mast and inspect the mast. Use a putty knife or similar tool to remove all loose flakes in the mast. Do not over lubricate the mast channels. A small amount is desirable, but excessive lubrication becomes contaminated with the metal flakes and acts as an abrasive that can cause the side thrust bearings to fail prematurely.

## **SERVICE BULLETIN**

Normal maintenance procedures and component replacement timelines are different from a standard forklift mast. Depending on the hours of use, the size of the weight and offset of the load, the side thrust bearings may require replacement after 1000-2000 hours of service. Each application is different, but almost every application will require replacement once a year. If you have any questions or need additional help,

Please contact Superior Engineering, Inc.  
1-800-359-3052, Fax 1-864-231-6718  
Po Box 547  
Belton, SC 29627